

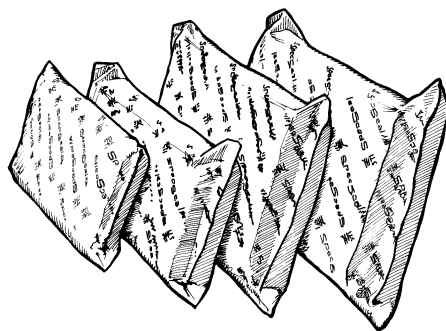

Reproduced from Electronic Media

PRODUCT DATA SHEET

Firestop Pillows



FEATURES

- **Intumescent:** Expands in all directions for a tough, tight seal.
- **Reinstallable** for easy retrofitting of cables.
- **Lightweight** for ease of installation. Easier wire screen requirements.
- **Heat-Sealed Poly Bag:** Strong & durable. No sewn seams to unravel or tear. No irritating fiberglass. Slide in and out easier.
- **Monolithic Encapsulated Core**
No loose fill!
- **No Special Tools Required!**
- **Superior Air Leakage Ratings!**



3L73

FILL, VOID OR CAVITY MATERIALS
CLASSIFIED BY UNDERWRITERS
LABORATORIES INC. ® FOR USE IN
THROUGH-PENETRATION
FIRESTOP SYSTEMS.

SEE UL FIRE RESISTANCE DIRECTORY



CLASSIFIED FILL, VOID, OR CAVITY
MATERIALS FOR USE IN THROUGH-
PENETRATION FIRESTOP SYSTEMS.
SEE UL DIRECTORY OF PRODUCTS
CERTIFIED FOR CANADA AND
UL FIRE RESISTANCE DIRECTORY

1. PRODUCT DESCRIPTION

SpecSeal® Firestop Pillows are through-penetration firestop products resembling small cushions or soft bricks. These intumescent and highly resilient pillows are installed in openings by compressing and stacking into the opening in a brick-like fashion.

SpecSeal® Firestop Pillows consists of a mineral fiber core material sealed with a water-resistant intumescent membrane. This coated core material is then heat-sealed in a tough, nonirritating, fire-retardant poly bag.

2. APPLICATIONS

SpecSeal® Firestop Pillows are particularly well suited for firestopping medium to large openings utilizing data, communications, power, or control cables, innerduct, and cable trays. This method of sealing offers easy retrofitting of cable installations without the need to damage the firestop seal. Difficult applications such as one-sided shaft wall installations may be easily firestopped with this material.

LIMITATIONS: In service temperatures must not exceed 150°F (65°C). Firestop pillows are not suitable for wet locations. Do not expose product to chemical environments that are harmful to LDPE (low density polyethylene).

PILLOWS ARE NOT DESIGNED TO BE USED AS A CABLE SUPPORT SYSTEM.

Cables must be independently supported to prevent their weight from resting upon the pillows.

3. PHYSICAL PROPERTIES

See Table A

4. PERFORMANCE

SSB Pillows are the basis for systems that meet the exacting criteria of ASTM E814 (UL1479) as well as the time-temperature requirements of ASTM E814. Tested systems will provide up to a four-hour rating for penetrations through concrete, CMU, or concrete tilt-up walls, as well as concrete or concrete over steel deck floors. Additional systems have been tested up to three hours in gypsum board walls.

AIR LEAKAGE: Tests conducted by Underwriters Laboratories for air leakage at ambient and elevated temperatures (400°) indicate that properly installed pillows seal penetrations virtually airtight.

5. SPECIFICATIONS

The firestopping system shall utilize an intumescent pillow heat sealed in a fire-retardant poly bag. The firestop pillow shall consist of a monolithic (one piece) core that is encapsulated on all sides by a flexible intumescent coating and shall not contain any loose fiber fill. The pillow shall be UL Classified and/or FM Systems Approved and tested to the requirements of ASTM E814 (UL1479).

SPECIFIED DIVISIONS

DIV.	7	07840	Through-Penetration Firestopping
DIV.	13	13900	Special Construction Fire Suppression & Supervisory Systems
DIV.	15	15250	Mechanical Insulation – Fire Protection
DIV.	16	16050	Basic Electrical Materials & Methods

Table A: PHYSICAL PROPERTIES

Product Name	SSB Series Firestop Pillows
Color	Red
Nom. Density	4 PCF (53kg/m3)
In-Service Temp.	≤ 130°F
Flammability*	V-0
Compression**	25% - 33%
Air Leakage	Less than 1 CFM/sq ft
(L Rating)	UL1479 (Pillows Only)
* Outer poly bag.	
** As installed.	

Fig. 1: CABLE TRAYS - FLOORS & WALLS

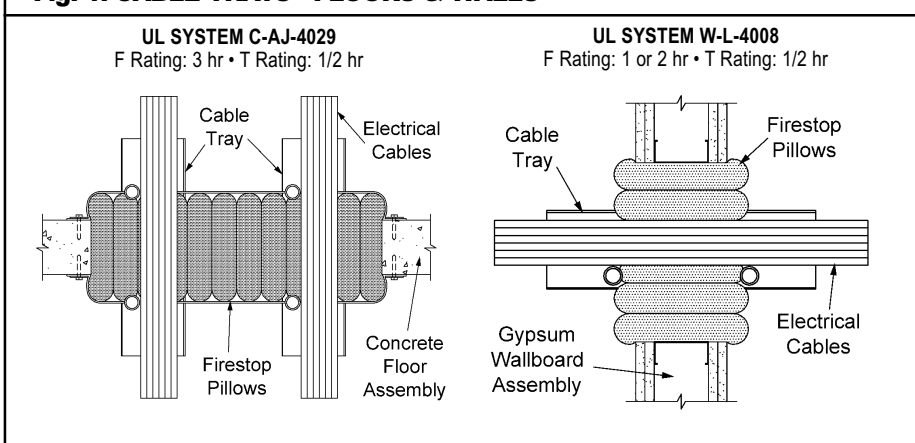

6. INSTALLATION INSTRUCTIONS

GENERAL: Inspect areas to be protected. Remove any sharp edges or protruding wires or ties that could damage poly bags. Arrange cables (if possible) to present a smooth and even surface. Eliminate large voids by filling with SpecSeal® Firestop Putty at egress from floor or wall surfaces. Calculate pillow requirements in square inches in advance of installation as an indicator of the proper installed volume and compression. See Estimation Table for instructions concerning proper estimation techniques.

SYSTEM SELECTION: Consult UL® Fire Resistance Directory, STI Product & Application Guide, or drawings provided by the manufacturer for specific details concerning installation design and requirements.

WIRE MESH: Some installations may require the installation of wire mesh as either an integral part of the system or as an option to facilitate installation. In systems where mesh is required, wound 20 gauge galvanized steel, 1" diamond mesh (e.g. poultry screen) is

recommended. Do not use soldered mesh or wire cloth. Secure wire mesh to wall or floor surfaces using steel fasteners and fender washers as required by the particular system chosen for use. Install wire mesh on one side of wall or on the lower side in floor applications before installing pillows.

INSTALLATION OF PILLOWS: All pillow sizes are 9" long. For the sake of clarity, we will refer to this dimension as the length. The next longest dimension will be referred to as the width. The shortest dimension

Table B: PRODUCT ESTIMATION INFORMATION

NOMINAL CROSS-SECTIONAL AREA OF PILLOWS				
CAT. NO.	SSB14	SSB24	SSB26	SSB36
Nom. Dim ^A	1" x 4"	2" x 4"	2" x 6"	3" x 6"
in cm	2.54 x 10.2	5.1 x 10.2	5.1 x 15.24	7.6 x 15.24
Nom. Area ^B	4 in ²	8 in ²	12 in ²	18 in ²
	25.8 cm ²	51.6 cm ²	77.4 cm ²	116 cm ²
Effective Yield ^C	2.9 in ²	5.7 in ²	8.6 in ²	12.9 in ²
	18.7 cm ²	36.8 cm ²	55.5 cm ²	83.2 cm ²

NOTES: PILLOW LENGTH = 9" (22.9cm).
^A Nom dimensions (uncompressed)
^B Cross-sectional area (uncompressed)
^C Cross-sectional area (compressed)

CALCULATING PILLOW REQUIREMENT

Measure the size of the opening to be sealed and calculate the total area of the opening in square inches. Measure and calculate the approximate area occupied by the penetrants. Calculate the net area to be sealed by subtracting the area occupied by the penetrants from the total area of the opening. To allow for the required compression of the pillows, multiply the net area by 1.4. This will provide a compression factor of 29%.

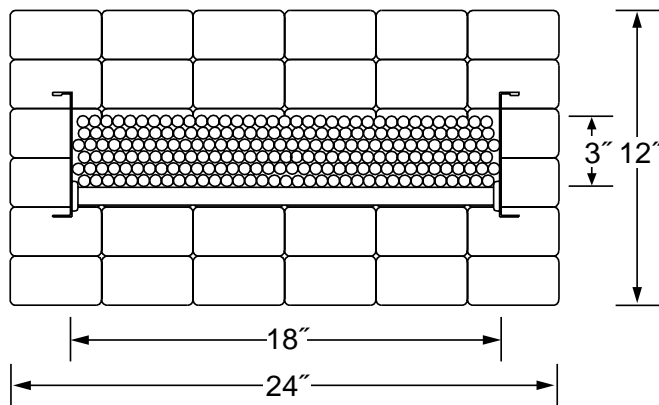

In the example shown at left, the opening is 12" x 24" with an 18" wide tray. The cable depth in the tray is about 3". The area of the opening is 12 x 24 = 288 sq. in. The approximate area of the cables is 3 x 18 = 54 sq. in. Subtracting the area of the cables from the total area of the opening yields a net area of 234 sq. in. 234 x 1.4 = approx. 328 sq. in. to be filled by pillows. Using the table at left to determine the nominal area of the various pillows, we can determine that approximately 28 (328 ÷ 12) SSB26 pillows would be required. The number of pillows required will of course vary by the size of the pillow being utilized. Generally, a small percentage of smaller pillows will be required along with the larger ones. A test opening of this size utilized 24 SSB26 pillows, along with 4 SSB24's and 4 SSB14's.

INSTALLATION OF SPECSEAL PILLOWS

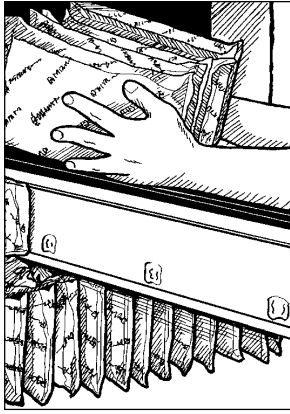

1. Install pillows lengthwise through the opening. Pillows may be stacked and installed in groups as shown above.

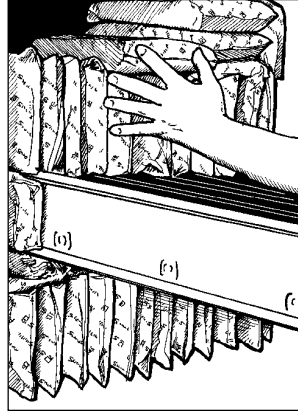

2. Pillows installed on edge will follow the contour of the cables more closely. Pillows may be installed laying flat as shown at the top of the penetration or on edge.



3. Smaller pillows are used to pack the smaller voids such as the space created by the tray rail. SpecSeal® Firestop Putty is used to seal any small voids at the cable line.

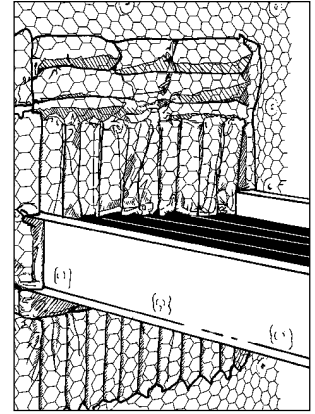

4. Check to make sure pillows are tightly compressed and all voids are closed. (If required by design, attach mesh using suitable fasteners to cover pillows and prevent unintentional or unauthorized removal).

will be referred to as the thickness. Pillows are installed by insertion through the opening in a lengthwise direction to form a 9" thick seal. Center pillows in opening so that they extend an equal distance out from the centerline of the wall or floor.

Orientation of the pillows may be either with the width (wide side) parallel or perpendicular to cables. If cable face in trays is uneven, pillows installed perpendicular to cables may form a tighter, more uniform seal. Install all pillows in a manner that ensures that they will be compressed (in both width

and thickness) to form tight seams between the bags with no voids or gaps. Smaller pillows may be used to seal appropriately sized gaps that may occur above or below cable tray rungs, etc. Pack SpecSeal Firestop Putty into any small voids between cables and pillows, tray and cables, tray and bags, bag to bag, or bag to wall or floor interface.

Complete installation by installing wire mesh on remaining wall or floor surface as required by design system being used. Generally, a 2" - 3" overlap of the surrounding wall or floor surface is

required. Install fasteners on 6" centers. A steel fender washer of sufficient diameter to completely overlap the opening through the mesh is required.

The mesh may be fastened to concrete floors or concrete or CMU walls using suitable steel anchors (e.g. Tapcon® Fasteners by ITW Ramset).

For hollow gypsum wallboard assemblies, attach mesh to the face of the wall using self-tapping, gypsum wallboard screws run into the framing members surrounding the opening.

USING SPECSEAL MORTAR TO REDUCE OPENING SIZE

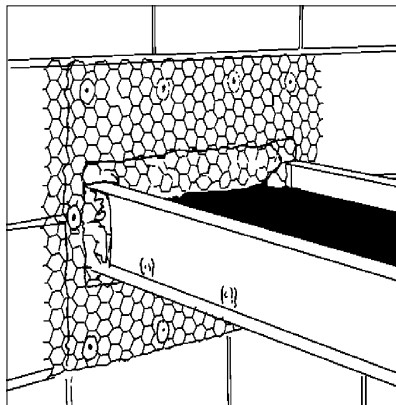
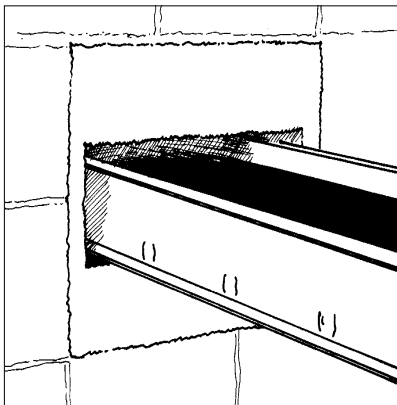

In the two photos shown above, SpecSeal Firestop Mortar has been installed around the cable tray as an economical void filler. In preparation, foam board forms are used to create the opening around the tray and to prevent leakage of the mortar from the wall cavity. After the mortar has dried, the forms are removed and the pillows are installed. Consult UL System No. C-AJ-4030 as well as the SpecSeal Firestop Mortar Product Data sheet for additional installation information.

BOTTOM-UP INSTALLATIONS!

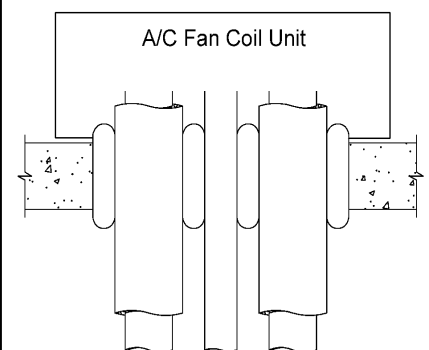

Pillows can be used to seal openings that are accessible only from the bottom as in this typical fan-coil installation. See UL System No. C-AJ-8052.

7. MAINTENANCE

INSPECTION: Installations should be inspected periodically for subsequent damage. Replace any damaged pillows.

RETROFIT: Cables may be added or replaced in previously sealed openings by removing the mesh and removing and replacing pillows as required. **DO NOT WEAVE CABLES THROUGH WIRE MESH!** Doing so may interfere with subsequent efforts to add or remove cables and may pose a safety hazard. Reinstall pillows and putty as required and then replace wire mesh.

NOTE: Removal of cables may require the installation of additional pillows to fill the void created by removing the cables. Inspect pillows for excess compression. SpecSeal Firestop Pillows are designed to be very durable and highly resilient. Excessive handling or abuse may permanently compress the pillows. If pillows are too thin to apply pressure within the seal when installed, replace thin pillows or add additional new pillows as required.

8. TECHNICAL SERVICE

Specified Technologies Inc. provides toll free technical support to assist in product selection and appropriate installation design. Design System Drawings suitable for submittal or specification purposes are available on request.

9. PRECAUTIONARY INFORMATION

Consult Material Safety Data Sheet for additional information on the safe handling and disposal of this material. Avoid damaging poly outer bag. Do not use damaged pillows.

10. AVAILABILITY

SpecSeal® Firestop Pillows are produced in four convenient sizes and are available from authorized distributors. Consult factory for the names and locations of the nearest sales representatives or distributors.

RETROFITTING

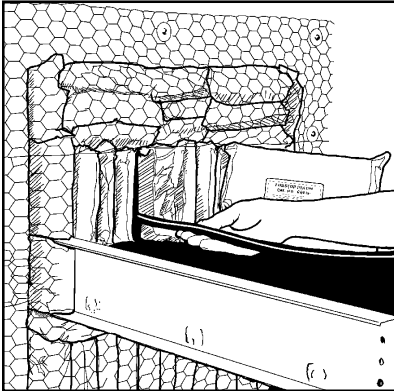

1. Cut & fold back wire mesh in the area to be modified.
2. Remove only the pillow or pillows necessary to accommodate the change.
3. Modify cables.
4. Reinstall pillow(s).
5. Re-close wire mesh and fasten wire mesh together using 20 gauge steel wire.

Table C: ORDERING INFORMATION

Cat. No.	Dimensions	Case Quan.
SSB14	1" x 4" x 9"	10
SSB24	2" x 4" x 9"	20
SSB26	2" x 6" x 9"	22
SSB36	3" x 6" x 9"	16



Additional SpecSeal Products...

Series LC150 Sealant	An economical latex firestop sealant for noncombustible applications. Non-halogenated, easy clean up, flexible, water-resistant!
SSP Firestop Putty	Available both in bar form and in pads, putty provides easy retrofit for through-penetrations and economical protection for electrical boxes.
Firestop Mortar	Lightweight, versatile and economical! The best choice for large or complex installations.
Pensil® Silicones	Sealants and foam for through-penetrations and construction joints. Unexcelled aging characteristics and flexibility.
Intumescent Wrap Strips	Two grades of intumescent wrap strips provide an unmatched combination of flexibility, economy, and expansion (up to 30X). Systems for plastic pipes including FR Polypropylene up to 8" trade size!
Molded Firestop Collars	Easy to install, economical protection for ABS and PVC pipes (both solid and foam core) as well as CPVC, PVDF, and FRPP. Collars available up to 6" trade size.
Elastomeric Joint Seals	New economical products for sealing construction joints. Choose caulk or spray applied products tested to UL2079.

CITY OF NEW YORK MEA 39-96M

Important Notice: All statements, technical information, and recommendations contained herein are based upon testing believed to be reliable, but the accuracy and completeness thereof is not guaranteed.

WARRANTY: Specified Technologies Inc. manufactures its goods in a manner to be free of defects. Should any defect occur in its goods (within one year), Specified Technologies Inc., upon prompt notification, will at its option, exchange or repair the goods or refund the purchase price.

Limitations and Exclusions: THIS WARRANTY IS IN LIEU OF ALL OTHER REPRESENTATIONS EXPRESSED OR IMPLIED (INCLUDING THE IMPLIED WARRANTIES OF MERCHANTABILITY OR FITNESS FOR USE) AND UNDER NO CIRCUMSTANCES SHALL SPECIFIED TECHNOLOGIES INC. BE RESPONSIBLE FOR ANY INCIDENTAL OR CONSEQUENTIAL PROPERTY DAMAGE OR LOSSES. PRIOR TO USE, THE USER SHALL DETERMINE THE SUITABILITY OF THE PRODUCT FOR ITS INTENDED USE, AND THE USER ASSUMES ALL RISKS AND LIABILITY FOR SUBSEQUENT USE.

No statement or recommendation not contained herein shall have any force or effect unless in an agreement signed by officers of seller and manufacturer.

MADE IN THE USA – COPYRIGHT © 2000 SPECIFIED TECHNOLOGIES, INC.



200 Evans Way • Somerville, NJ 08876
Phone: (800) 992-1180 • Fax: (908) 526-9623
Facts-On-Demand: (888) 526-6800
STI on the WEB: www.stifirestop.com